

DIMENSÕES E ESPECIFICAÇÕES TÉCNICAS FORNOS PARA ASSAR PIZZA **PIETRO FORNOS**

MOD. TURBO AM 37/70 FLEX

VISTA LATERAL
001 FORNO

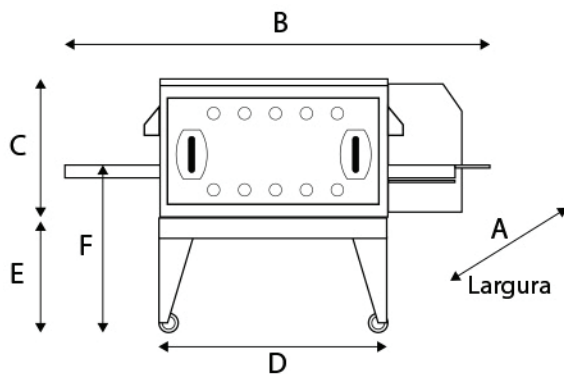

A	B	C	D	E
1125 mm	1725 mm	510 mm	750 mm	610 mm
F	Vel. Esteira	Larg. Esteira Malha/Moldura	Comp. Túnel	Temp. Máx.
845 mm	1 a 10 minutos	370 / 400 mm	700 mm	350 °C

VISTA LATERAL
002 FORNOS

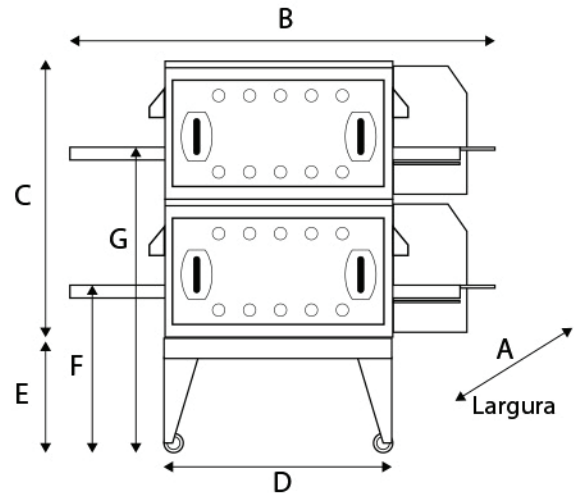

A	B	C	D	E	F
1125 mm	1725 mm	1020mm	750 mm	610 mm	845 mm
G	Vel. Esteira	Larg. Esteira Malha/Moldura	Comp. Túnel	Temp. Máx.	
1355 mm	1 a 10 min.	370 / 400 mm	700 mm	350 °C	

VISTA FRONTAL
001 FORNO

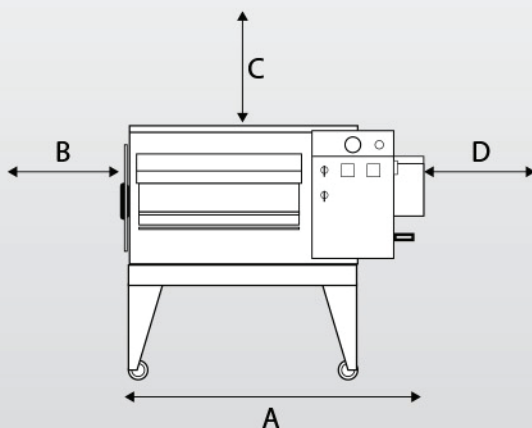

A	B	C	D
1125 mm	1000 mm	780 mm	20 mm

VISTA FRONTAL
002 FORNOS

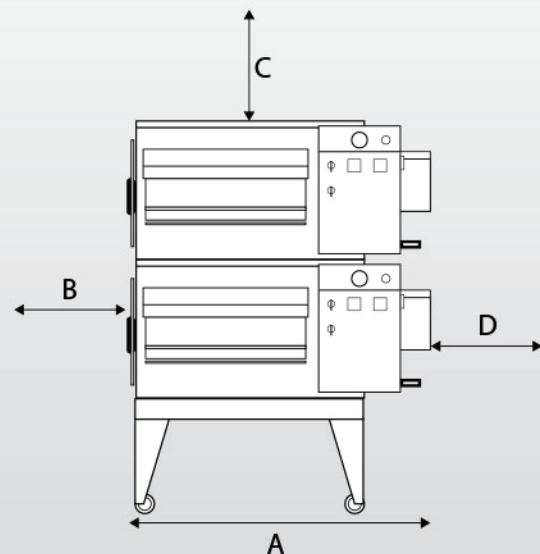

A	B	C	D
1125 mm	1000 mm	270 mm	20 mm

OBS: imagens meramente ilustrativas. Os equipamentos podem sofrer alterações sem aviso prévio.

DIMENSÕES E ESPECIFICAÇÕES TÉCNICAS FORNOS PARA ASSAR PIZZA **PIETRO FORNOS**

MOD. TURBO AM 37/70 FLEX

VISTA SUPERIOR
001 FORNO

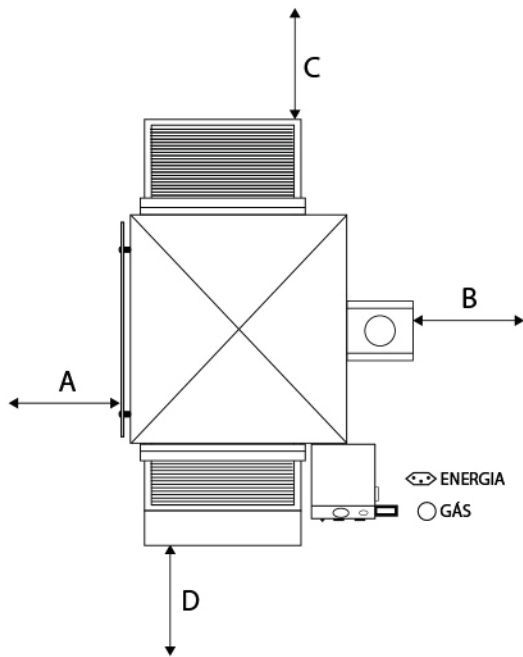

A	B	C	D
1000 mm	20 mm	500 mm	500 mm

VISTA SUPERIOR
002 FORNOS

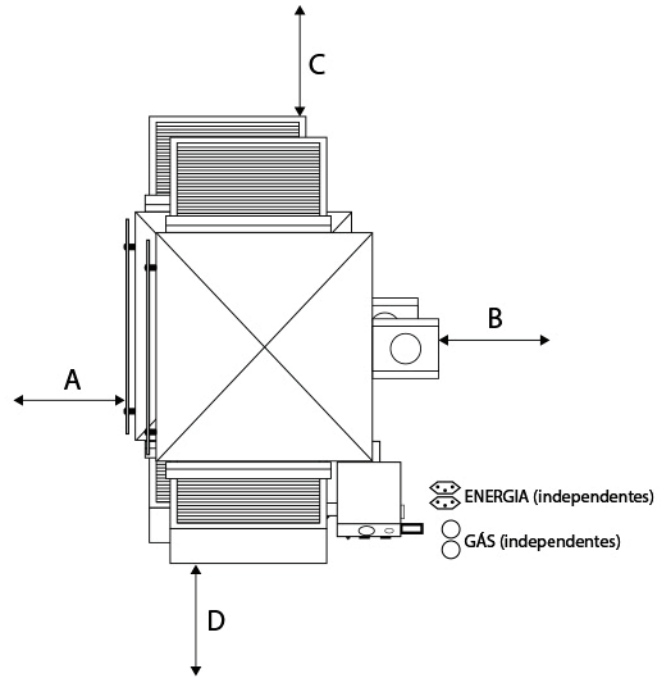

A	B	C	D
1000 mm	20 mm	500 mm	500 mm

COIFA PARA MOD. TURBO AM 37/70 FLEX

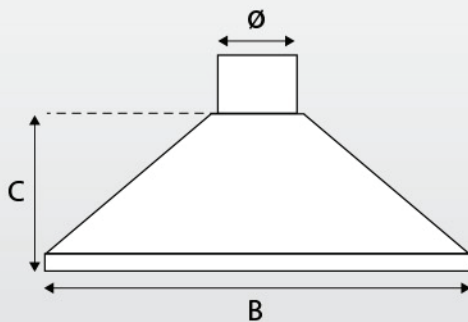

COIFA 001 FORNO

A	B	C	Ø
1625 mm	2225 mm	1200 mm	Conf. projeto

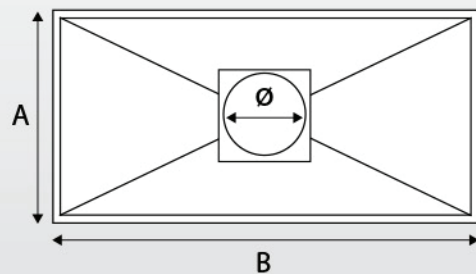

COIFA 002 FORNOS

A	B	C	Ø
1625 mm	2225 mm	1200 mm	Conf. projeto

OBS: imagens meramente ilustrativas. Os equipamentos podem sofrer alterações sem aviso prévio.