

# DIMENSÕES E ESPECIFICAÇÕES TÉCNICAS FORNOS PARA ASSAR PIZZA **PIETRO FORNOS**

## MOD. JUNIOR AM 45/50

VISTA LATERAL  
001 FORNO

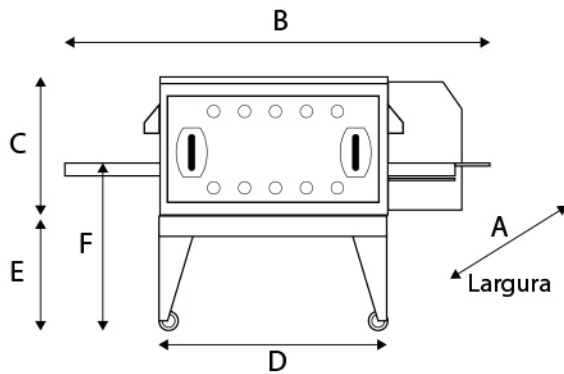

A	B	C	D	E
1030 mm	1490 mm	480 mm	840 mm	610 mm
F	Vel. Esteira	Larg. Esteira Malha/Moldura	Comp. Túnel	Temp. Máx.
810 mm	1 a 10 minutos	400 / 450 mm	500 mm	350 °C

VISTA LATERAL  
002 FORNOS

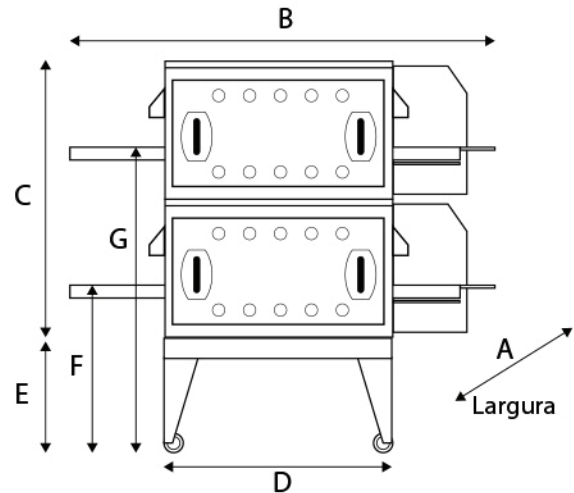

A	B	C	D	E	F
1030 mm	1490 mm	960 mm	840mm	610 mm	810 mm
G	Vel. Esteira	Larg. Esteira Malha/Moldura	Comp. Túnel	Temp. Máx.	
1290 mm	1 a 10 min.	400 / 450 mm	500 mm	350 °C	

VISTA FRONTAL  
001 FORNO

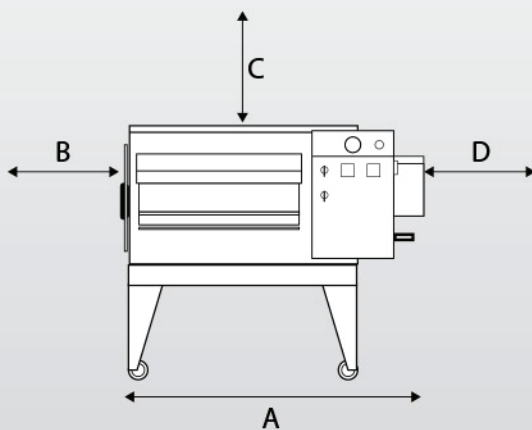

A	B	C	D
1030 mm	1000 mm	810 mm	20 mm

VISTA FRONTAL  
002 FORNOS

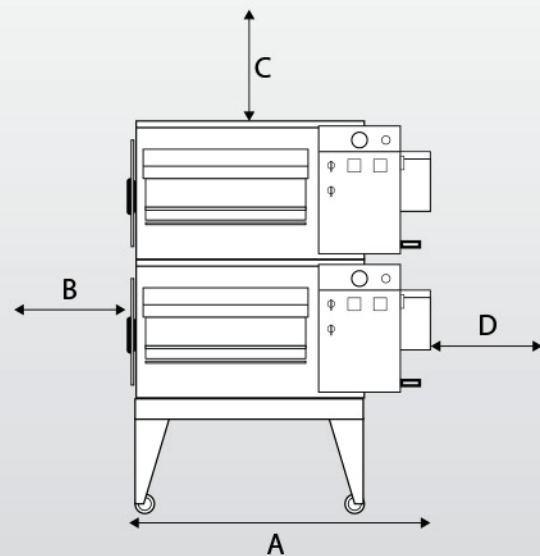

A	B	C	D
1030 mm	1000 mm	330 mm	20 mm

OBS: imagens meramente ilustrativas. Os equipamentos podem sofrer alterações sem aviso prévio.

# DIMENSÕES E ESPECIFICAÇÕES TÉCNICAS FORNOS PARA ASSAR PIZZA **PIETRO FORNOS**

## MOD. JUNIOR AM 45/50

VISTA SUPERIOR  
001 FORNO

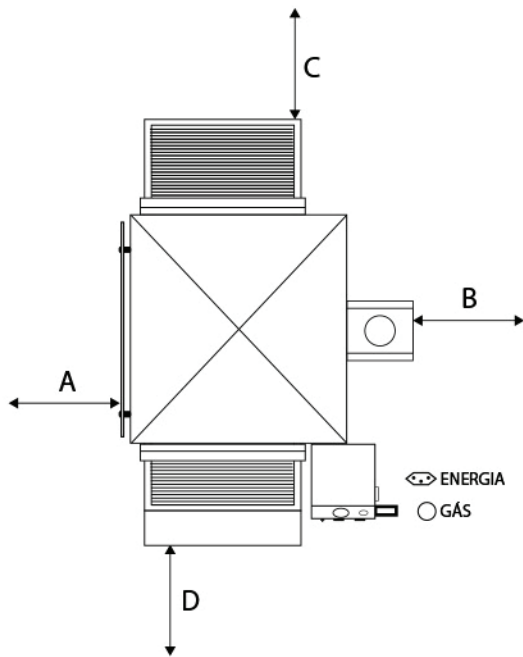

A	B	C	D
1000 mm	20 mm	500 mm	500 mm

VISTA SUPERIOR  
002 FORNOS

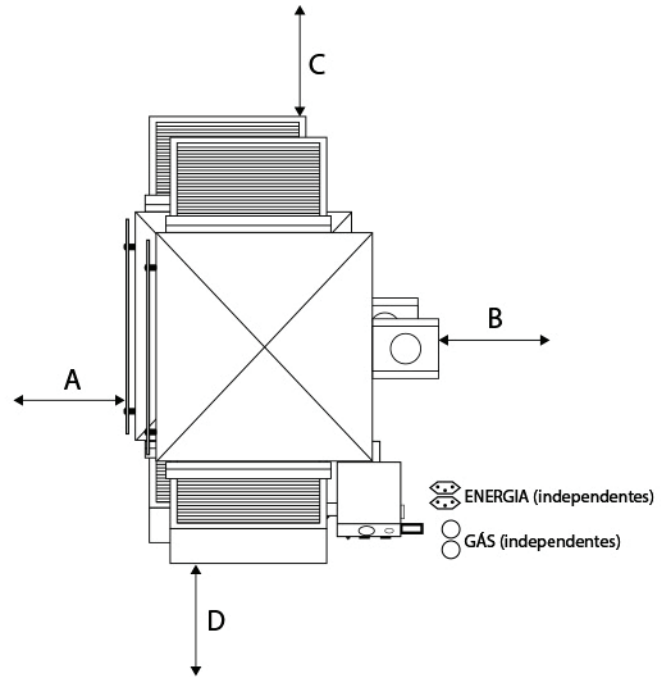

A	B	C	D
1000 mm	20 mm	500 mm	500 mm

## COIFA PARA MOD. JUNIOR AM 45/50

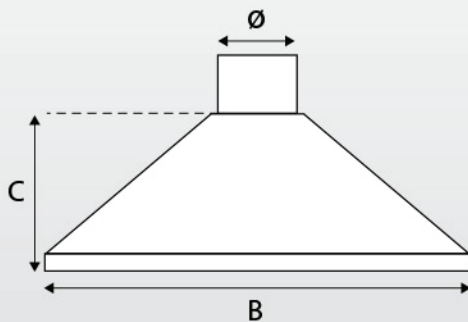

COIFA 001 FORNO

A	B	C	Ø
1530 mm	1990 mm	1200 mm	Conf. projeto

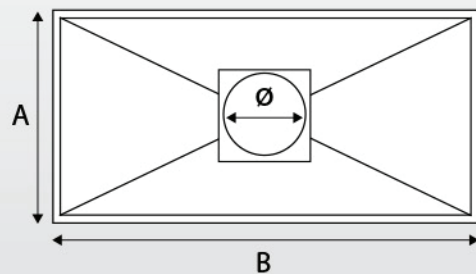

COIFA 002 FORNOS

A	B	C	Ø
1530 mm	1990 mm	1200 mm	Conf. projeto

OBS: imagens meramente ilustrativas. Os equipamentos podem sofrer alterações sem aviso prévio.