

DIMENSÕES E ESPECIFICAÇÕES TÉCNICAS FORNOS PARA ASSAR PIZZA PIETRO FORNOS

MOD. AM 85 1 GÁS ESTEIRA ALONGADA

VISTA LATERAL
001 FORNO

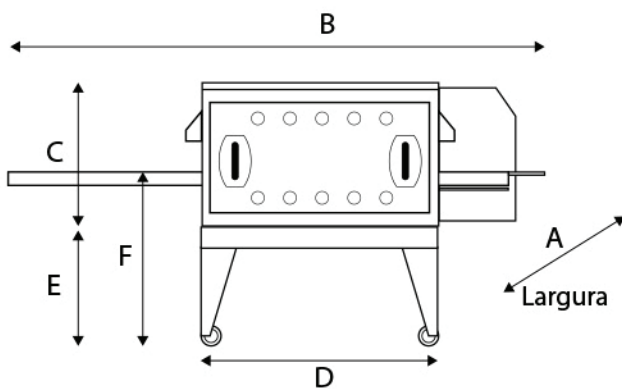

A	B	C	D	E
1600 mm	2655 mm	675 mm	1040 mm	680 mm
F	Vel. Esteira	Larg. Esteira Malha/Moldura	Comp. Túnel	Temp. Máx.
1000 mm	1 a 10 min.	800 / 840 mm	1000 mm	350 °C

VISTA LATERAL
002 FORNOS

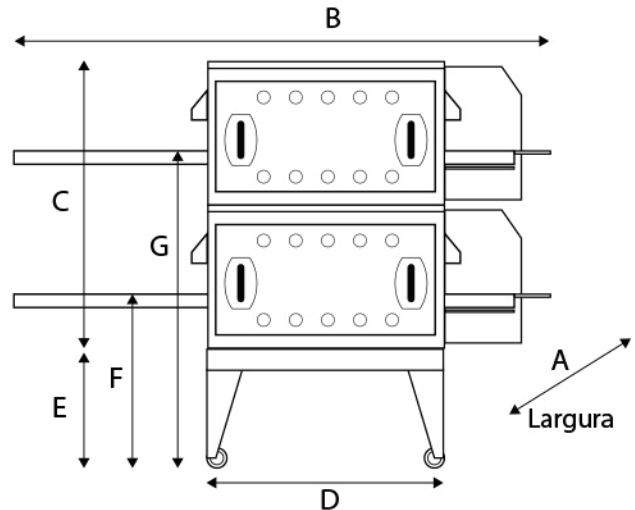

A	B	C	D	E	F
1600 mm	2655 mm	1350 mm	1040 mm	440 mm	760 mm
G	Vel. Esteira	Larg. Esteira Malha/Moldura	Comp. Túnel	Temp. Máx.	
1430 mm	1 a 10 min.	800 / 840 mm	1000 mm	350 °C	

VISTA FRONTAL
001 FORNO

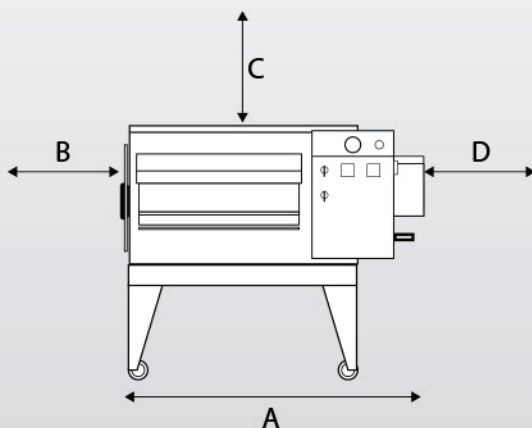

A	B	C	D
1600 mm	1000 mm	545 mm	20 mm

VISTA FRONTAL
002 FORNOS

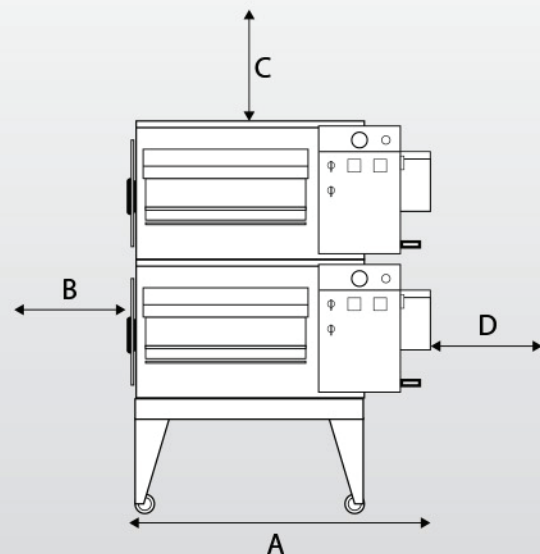

A	B	C	D
1600 mm	1000 mm	110 mm	20 mm

OBS: imagens meramente ilustrativas. Os equipamentos podem sofrer alterações sem aviso prévio.

DIMENSÕES E ESPECIFICAÇÕES TÉCNICAS FORNOS PARA ASSAR PIZZA PIETRO FORNOS

MOD. AM 85 1 GÁS ESTEIRA ALONGADA

VISTA SUPERIOR
001 FORNO

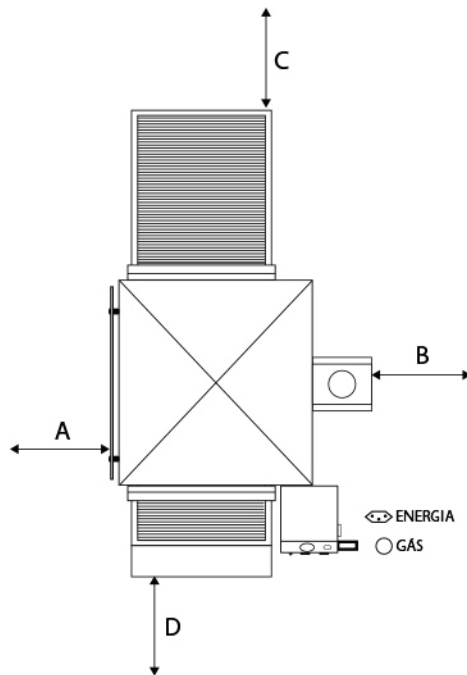

A	B	C	D
1000 mm	20 mm	500 mm	500 mm

VISTA SUPERIOR
002 FORNOS

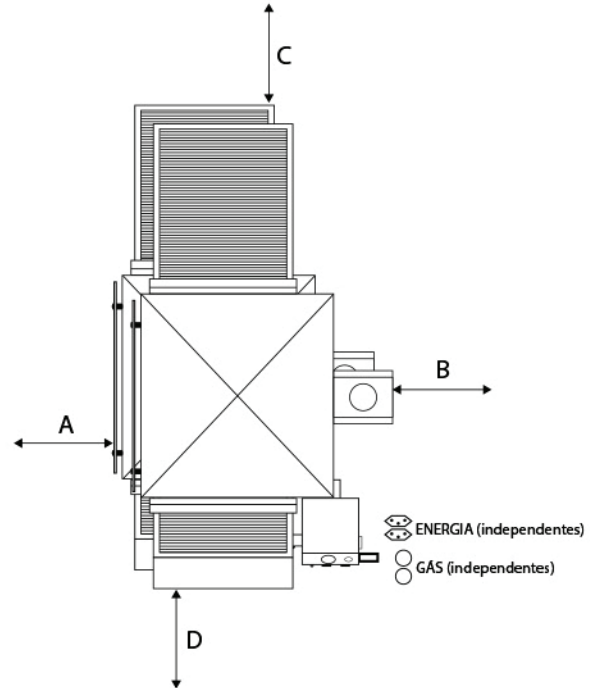

A	B	C	D
1000 mm	20 mm	500 mm	500 mm

COIFA PARA MOD. AM 85 1 GÁS ESTEIRA ALONGADA

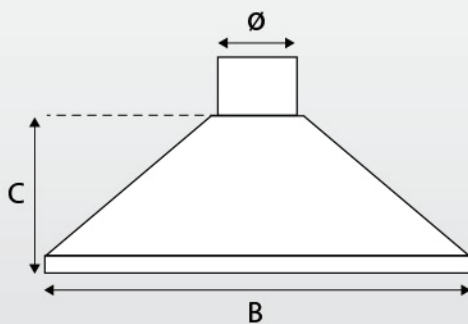

COIFA 001 FORNO

A	B	C	Ø
2100 mm	2655 mm	1200 mm	Conf. projeto

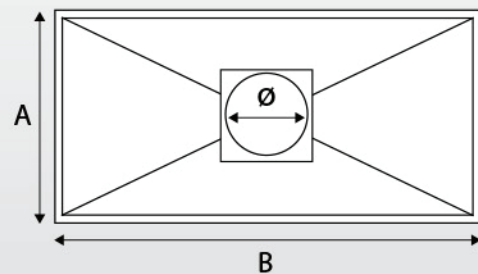

COIFA 002 FORNOS

A	B	C	Ø
2100 mm	2655 mm	1200 mm	Conf. projeto

OBS: imagens meramente ilustrativas. Os equipamentos podem sofrer alterações sem aviso prévio.